

1 Cast Stone Accents
• Dove Gray



2 Primary Building Stone
• Greenwich Gray Limestone



3 Building Roof Shingles
• Synthetic Slate, Slate Gray

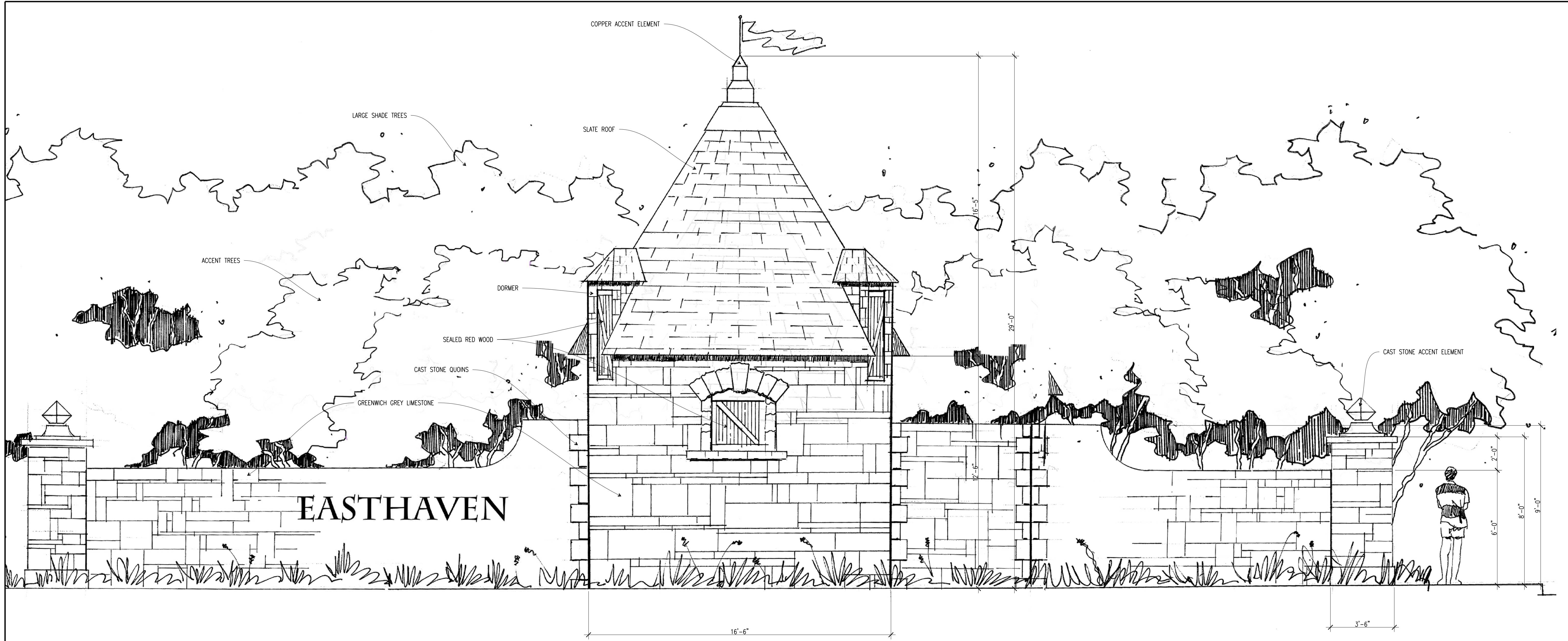

EASTHAVEN

C1 ENTRY MONUMENT ELEVATION
3/8"=1'-0"

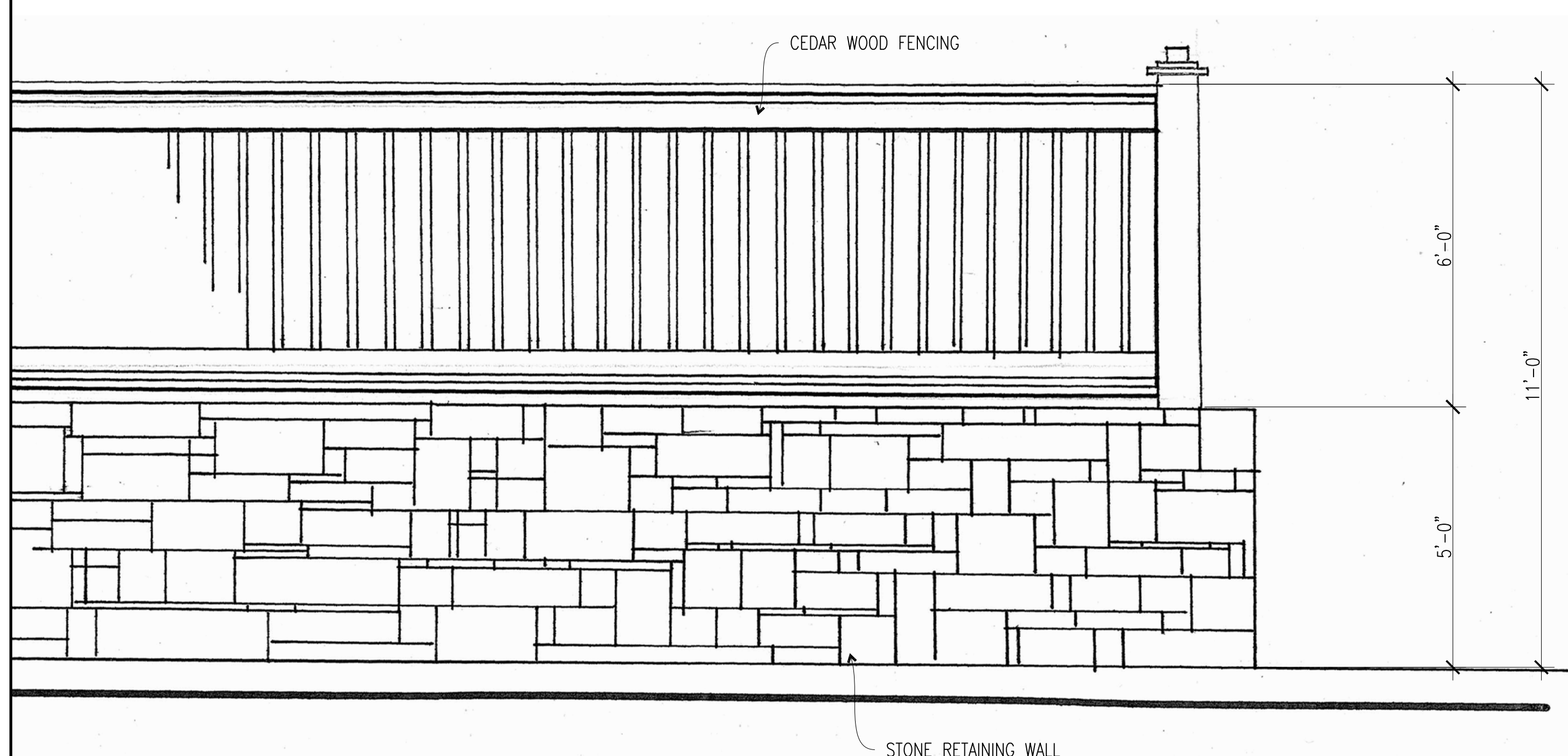

A1 RETAINING WALL AND FENCE ELEVATION
1/2"=1'-0"

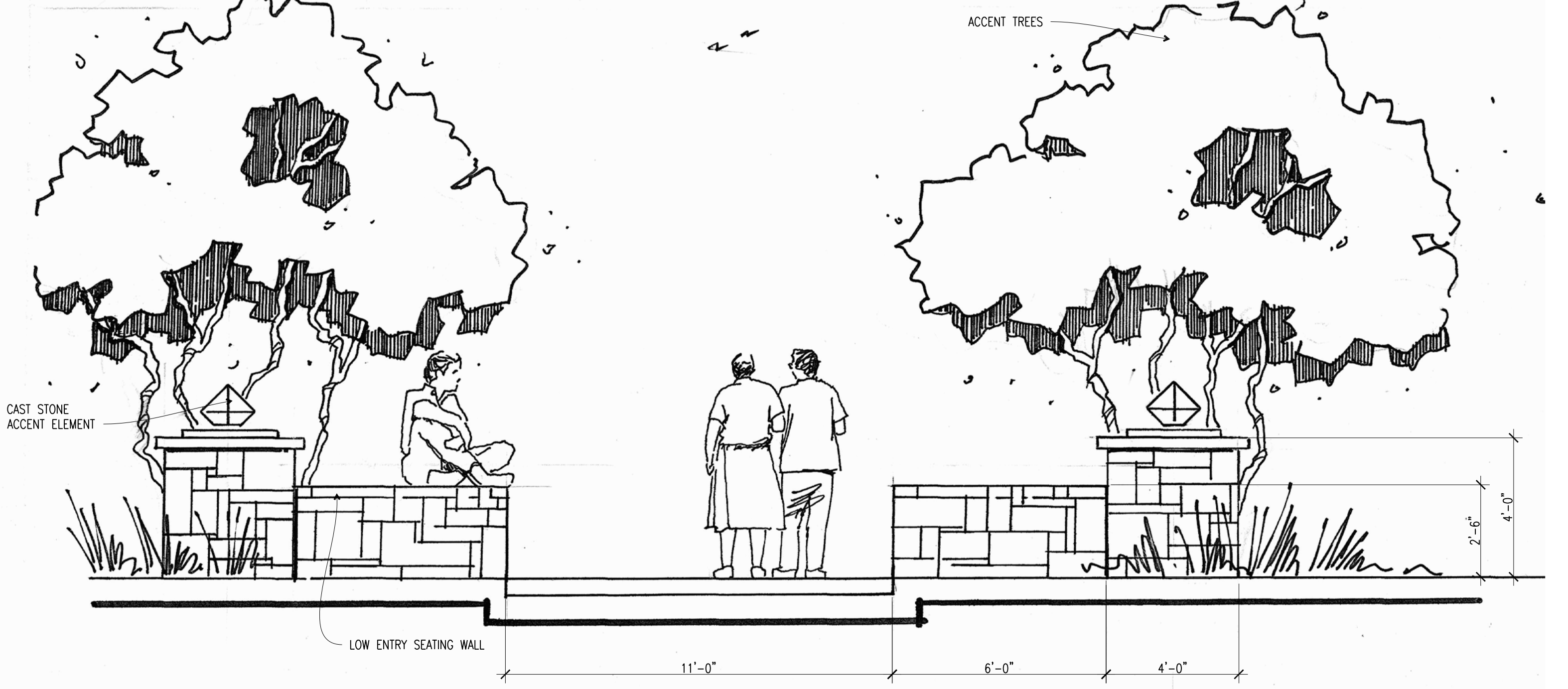

A7 RETAINING WALL AND FENCE ELEVATION
3/8"=1'-0"

DEVELOPER:
AMALGAMATED DEVELOPMENT, LP
5055 KELLER SPRINGS, SUITE 170
ADDISON, TX 75006
T 214-914-9809

PRELIMINARY
FOR REVIEW ONLY
These documents are for design review and not intended for construction, bidding, or permit purposes. They were prepared by or under the supervision of:
BRIAN D. ADAMS
Registered Landscape Architect
State of Texas #1676
April 16, 2012

CALLISON
1445 ROSS AVE., STE 2600
DALLAS, TX 75202
T 214 446 0950
F 214 446 0951
www.callison.com

EASTHAVEN
PD-264 RBN-5
Coppell, Texas
213849.00

ISSUED / REVISED	DATE
Preliminary Submittal	04/17/13
DRG Submittal	05/02/13
1st P&Z Submittal	05/07/13
1st Council Submittal	05/30/13

FOR REVIEW PURPOSES ONLY
LANDSCAPE DETAILS

L-04

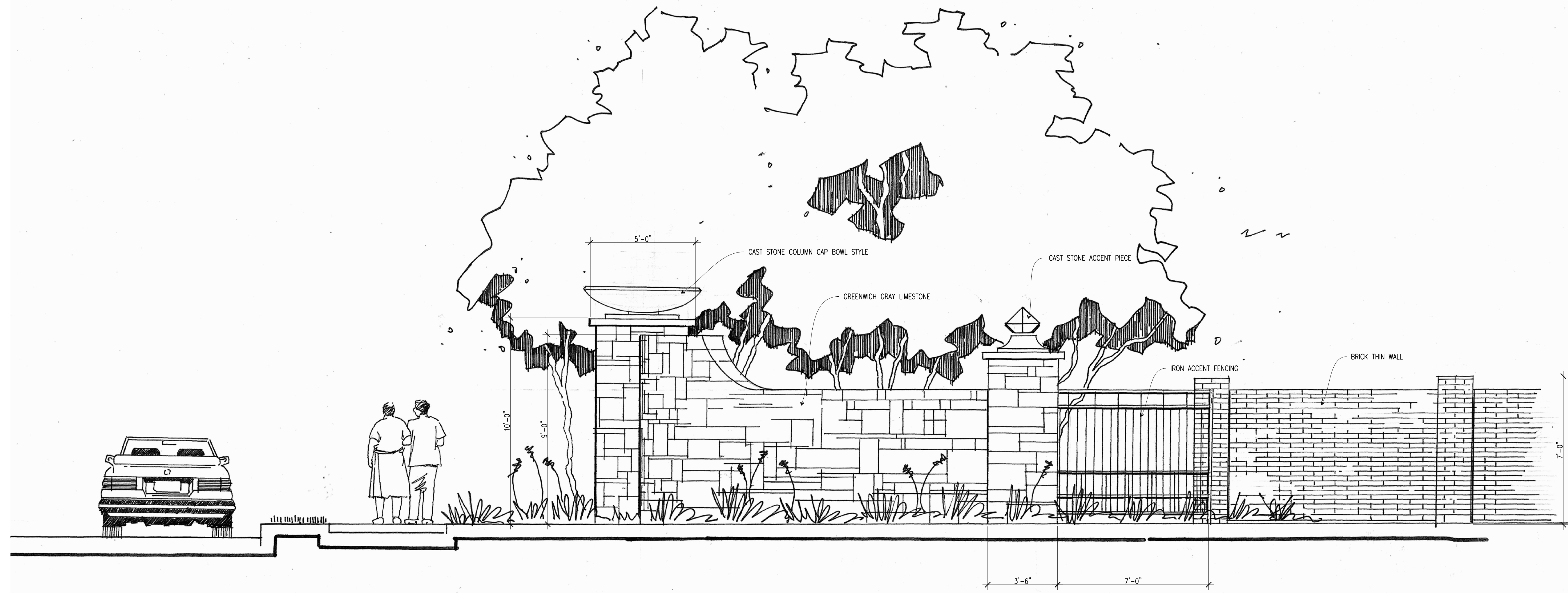

C1 MINOR ENTRY WALL ELEVATION
3/8"=1'-0"

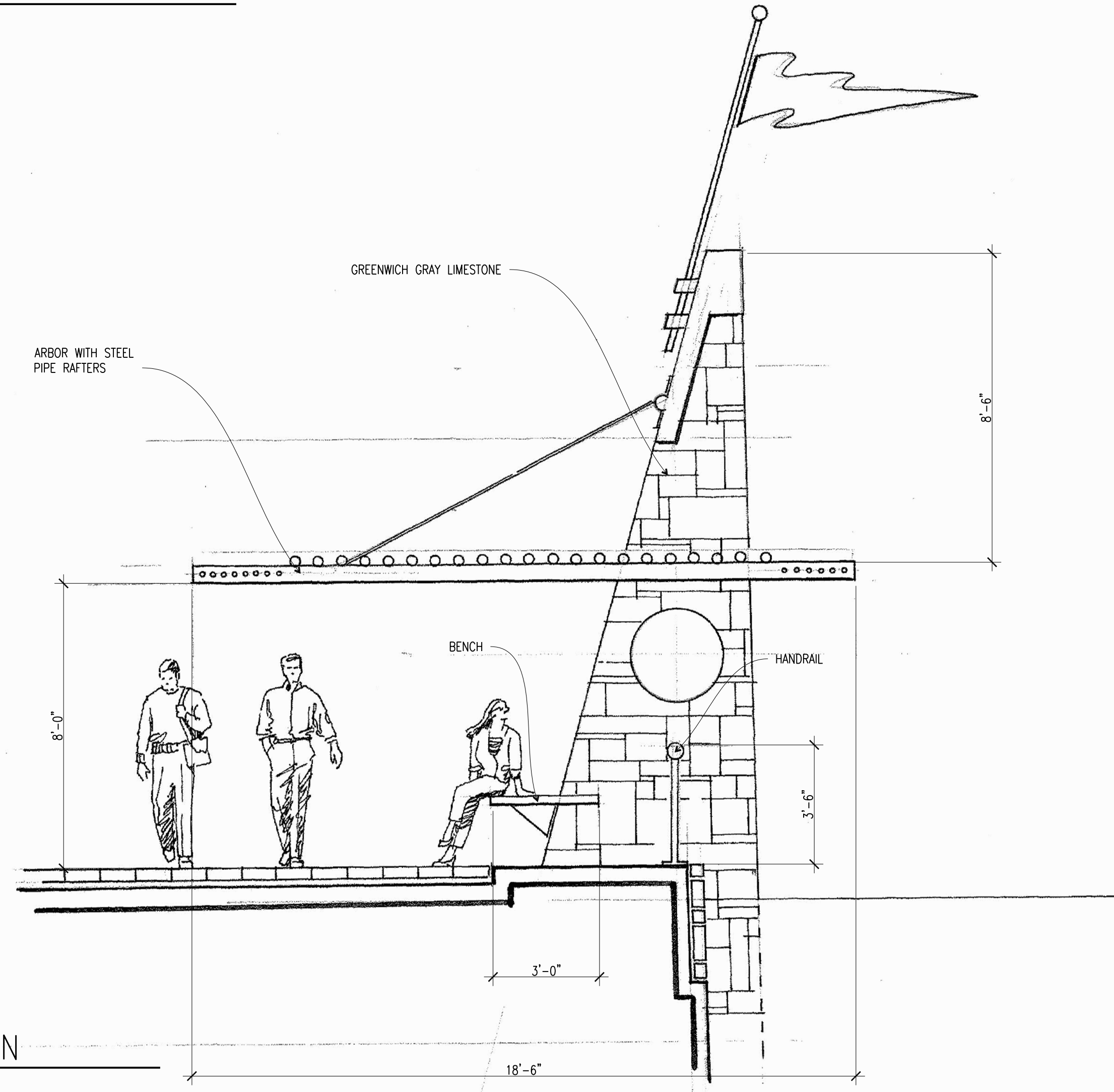

A1 ARBOR ELEVATION
3/8"=1'-0"

DEVELOPER:
AMALGAMATED DEVELOPMENT, LP
5055 KELLER SPRINGS, SUITE 170
ADDISON, TX 75006
T 214-914-9809

PRELIMINARY
FOR REVIEW ONLY
These documents are for design review and not intended for construction, bidding, or permit purposes. They were prepared by or under the supervision of:
BRIAN D. ADAMS
Registered Landscape Architect
State of Texas #1676
April 16, 2012

CALLISON
1445 ROSS AVE., STE 2600
DALLAS, TX 75202
T 214 446 0950
F 214 446 0951
www.callison.com

EASTHAVEN
PD-264 RBN-5
Coppell, Texas

ISSUED / REVISED	DATE
Preliminary Submittal	04/17/13
DRC Submittal	05/02/13
1st P&Z Submittal	05/07/13
1st Council Submittal	05/30/13

FOR REVIEW
PURPOSES ONLY
LANDSCAPE DETAILS

L-05

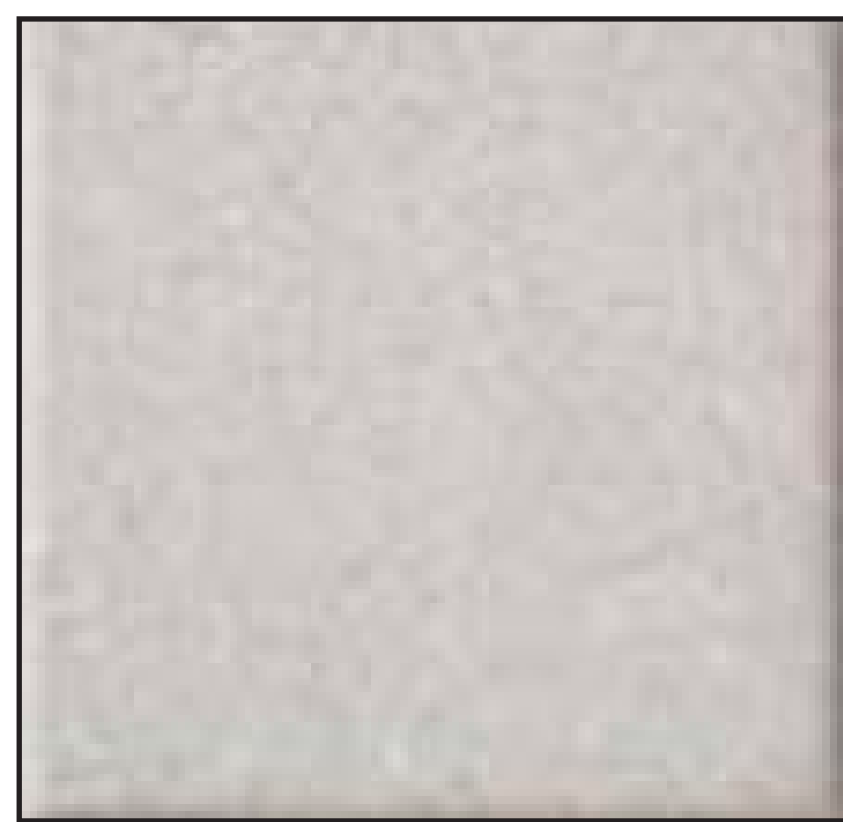
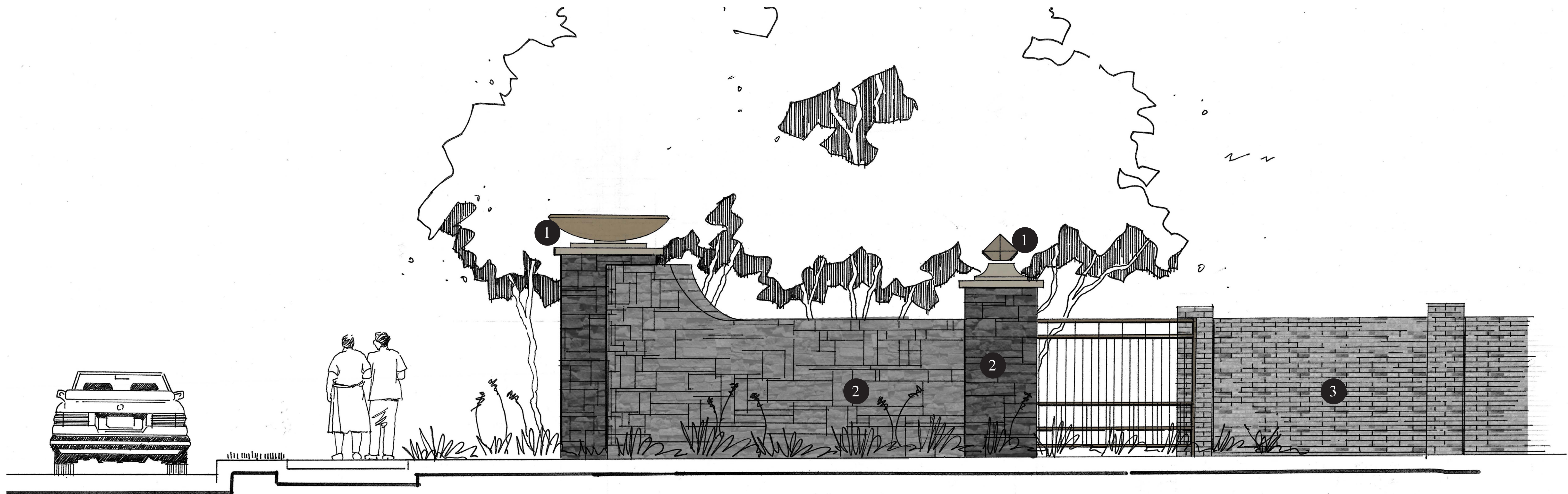

1 Cast Stone Accents
• Dove Gray



2 Primary Building Stone
• Greenwich Gray Limestone



3 Brick Thin Wall
• Cape Cod

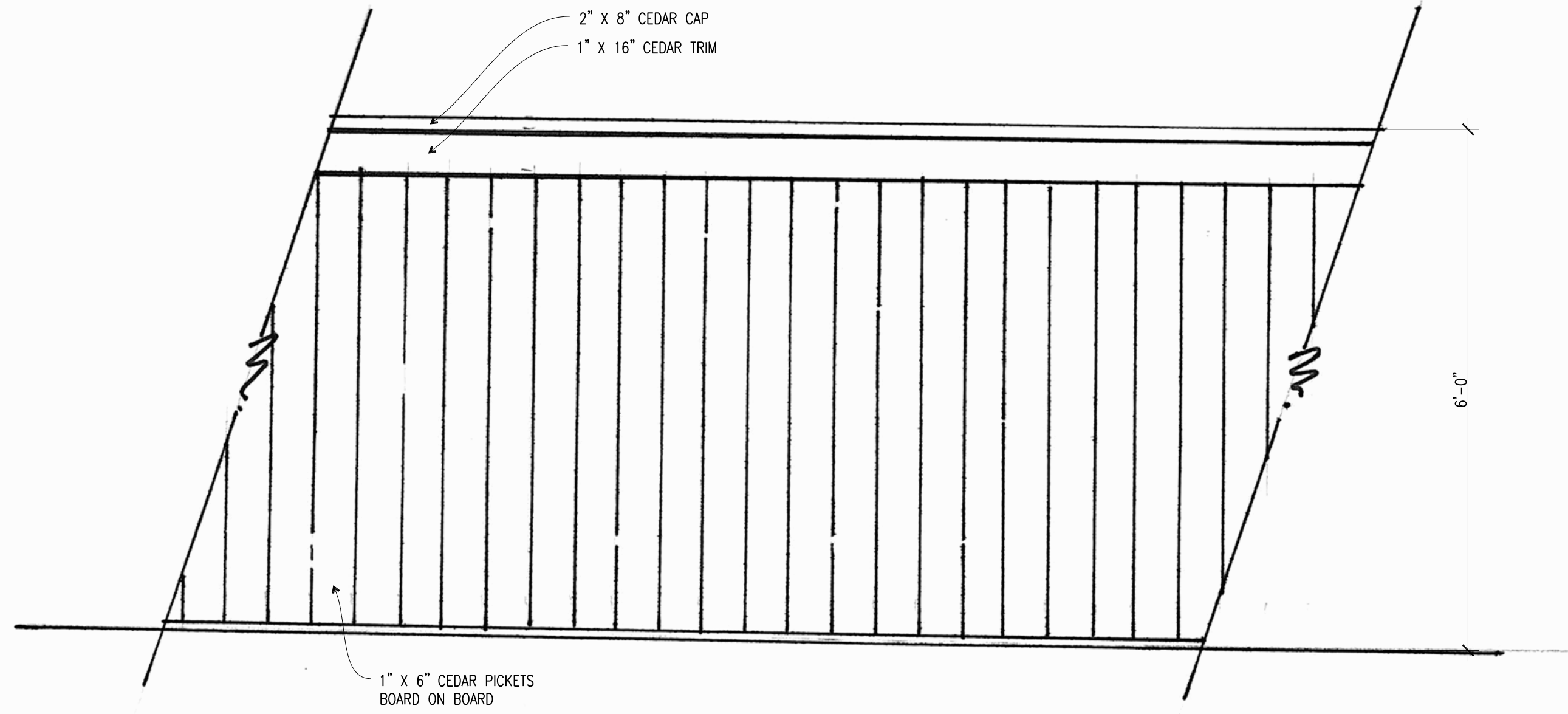

D1 CEDAR FENCE ELEVATION
3/4"=1'-0"

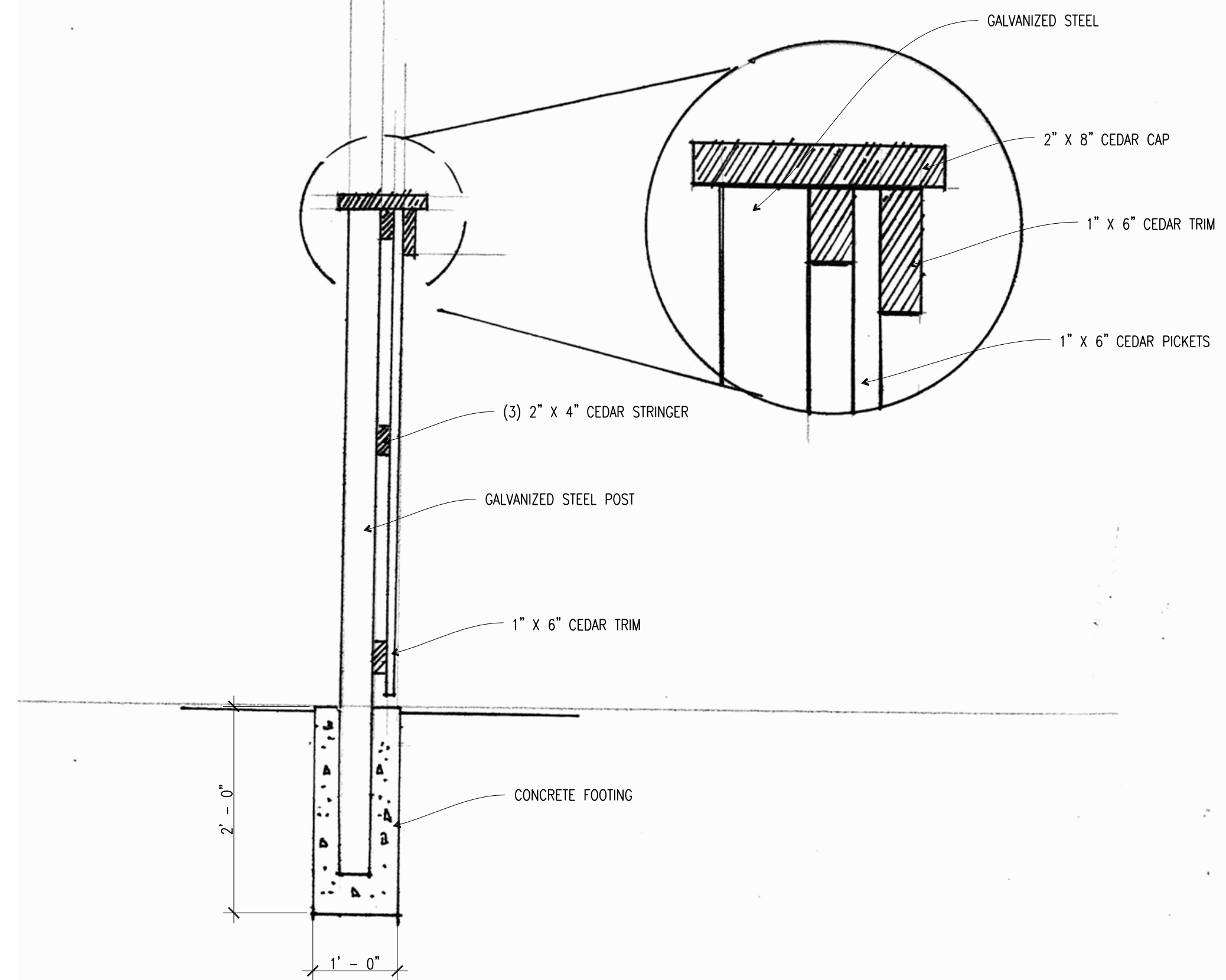

D7 CEDAR FENCE SECTION
3/4"=1'-0"

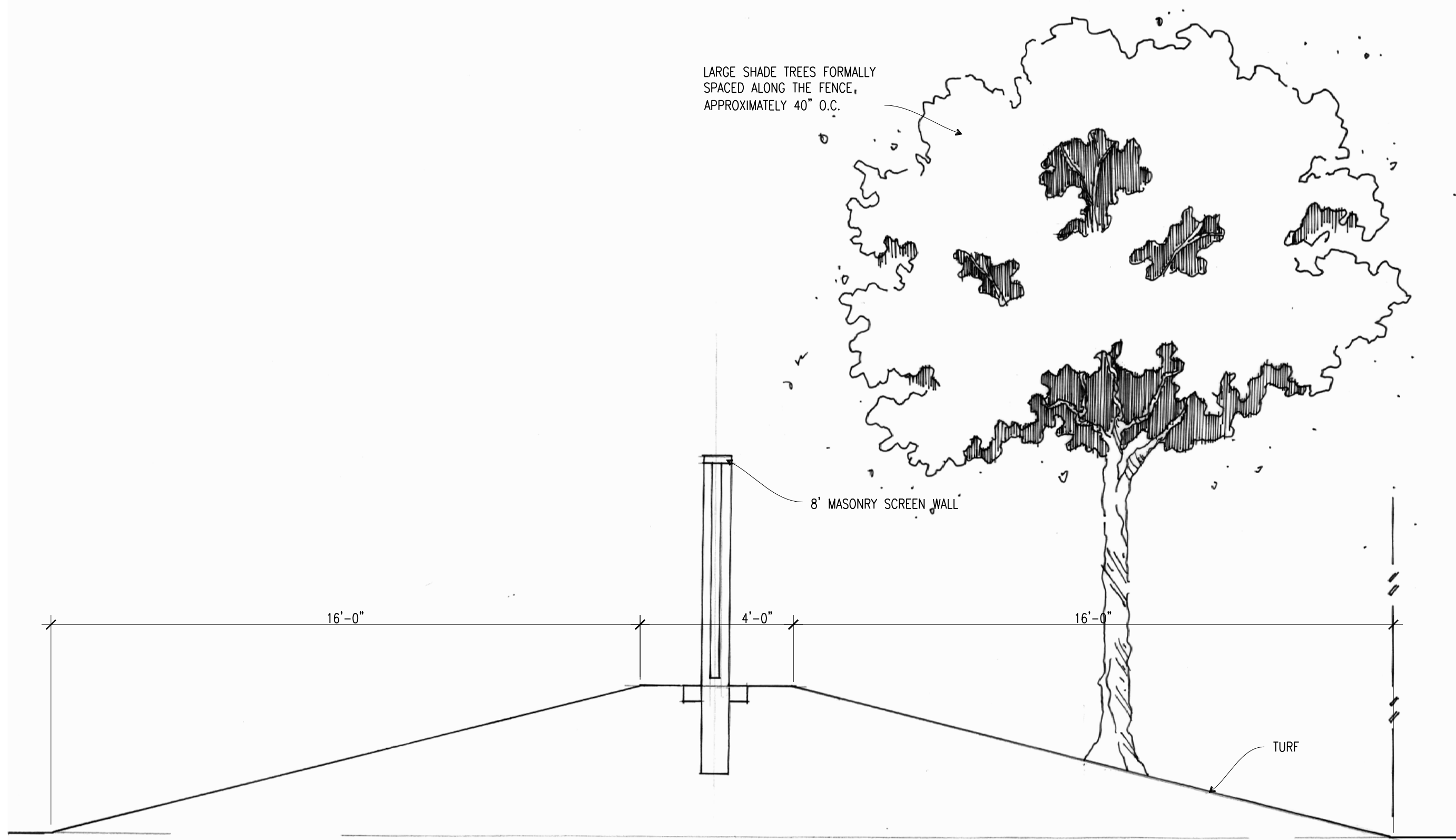

A1 SCREEN WALL ON BERM
3/8"=1'-0"

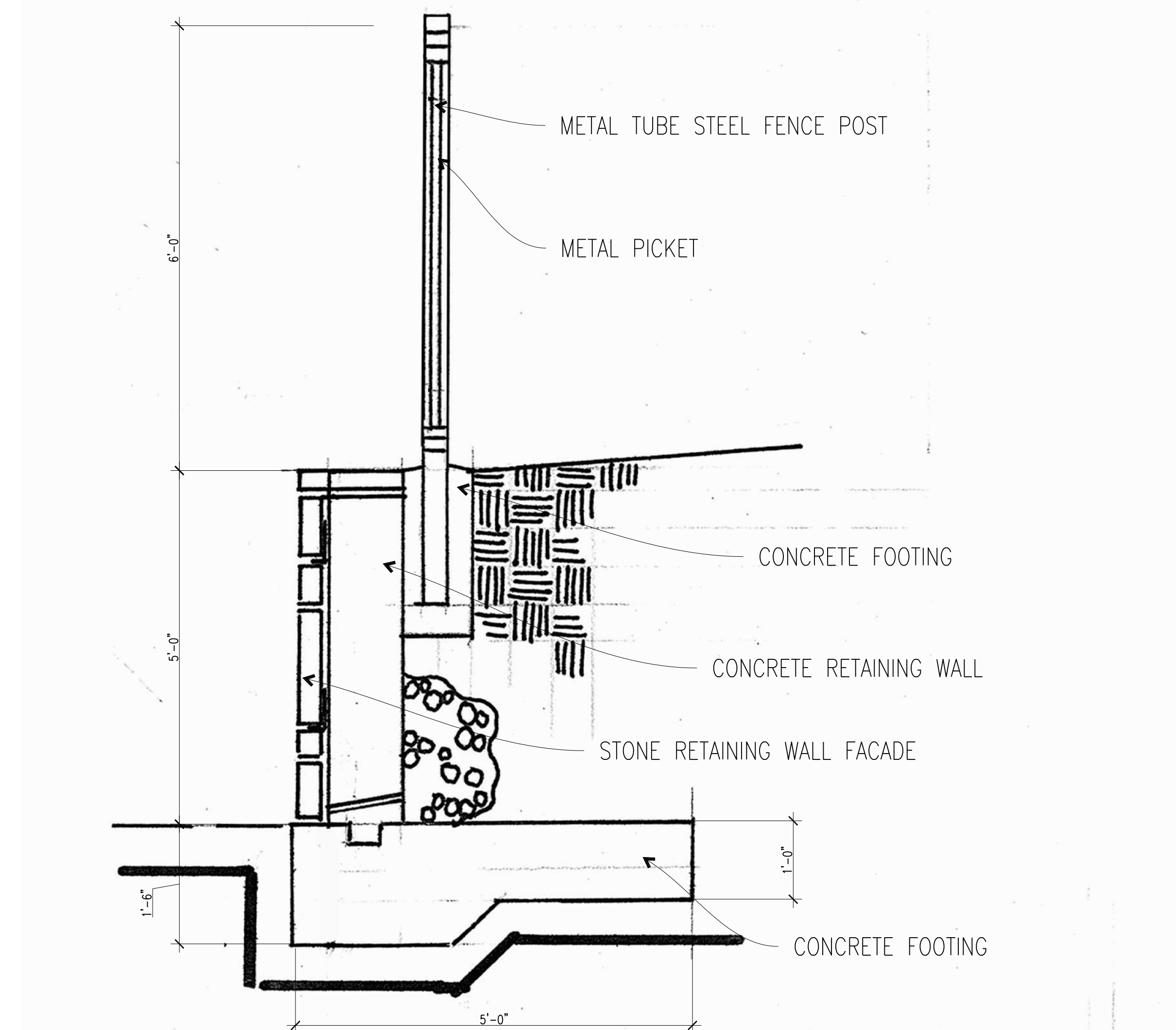

A7 RETAINING WALL AND FENCE SECTION
3/4"=1'-0"

DEVELOPER:
AMALGAMATED DEVELOPMENT, LP
5055 KELLER SPRINGS, SUITE 170
ADDISON, TX 75006
T 214-914-9809

PRELIMINARY
FOR REVIEW ONLY
These documents are for design review and not intended for construction, bidding, or permit purposes. They were prepared by or under the supervision of:
BRIAN D. ADAMS
Registered Landscape Architect
State of Texas #1676
April 16, 2012

CALLISON
1445 ROSS AVE., STE 2600
DALLAS, TX 75202
T 214 446 0950
F 214 446 0951
www.callison.com

EASTHAVEN
PD-264 RBN-5
Coppell, Texas

ISSUED / REVISED	DATE
Preliminary Submittal	04/17/13
DRC Submittal	05/02/13
1st P&Z Submittal	05/07/13
1st Council Submittal	05/30/13
2nd Council Submittal	06/21/13

FOR REVIEW PURPOSES ONLY
LANDSCAPE DETAILS

L-03