

PROPOSED FLOOR PLAN

SCALE 1/8" = 1'-0"

IECC 2015 GREEN/ENERGY CODE COMPLIANCE FOR HOME

ALL GREEN/ENERGY SYSTEMS MUST MEET THE REQUIREMENTS FROM THE CHAPTER 4 OF THE INTERNATIONAL ENERGY CONSERVATION CODE, REFERED TO RESIDENTIAL ENERGY EFFICIENCY. IF ANY ITEM IS NOT LISTED BELOW REFER TO THE MENTIONED CHAPTER.

- STORMWATER:**
 - 1.1. 70% OF NON-ROOF AREA HAS VEGETATIVE LANDSCAPE, PERMEABLE PAVING OR SLOPED FOR RUNOFF TO A PERMANENT FILTRATION FEATURE.
- WATER EFFICIENCY:**
 - 2.1. LAVATORY FAUCETS MUST HAVE AN AVERAGE FLOW RATE OF 2.0 GALLONS PER MINUTE OR LESS.
 - 2.2. SHOWERS HEADS MUST HAVE AN AVERAGE FLOW RATE OF 2.0 GALLONS PER MINUTE OR LESS.
 - 2.3. TOILETS MUST HAVE AN AVERAGE FLOW RATE OF:
 - 2.3.1. LESS THAN OR EQUAL TO 1.3 GALLONS PER FLUSH.
 - 2.3.2. DUAL FLUSH COMPLYING WITH ASME A 112.19.14.
 - 2.3.3. COMPLY WITH US EPA WATER SENSE.
 - 2.4. ENERGY STAR DISHWASHER.
 - 2.5. ENERGY STAR CLOTHES WASHER.
- HEAT ISLAND MITIGATION:**
 - 3.1. ENERGY STAR QUALIFIED ROOF SYSTEM FOR ROOF WITH SLOPE OF 2:12 OR GREATER.
 - 3.2. RADIANT BARRIER IN ATTIC WITH CONVENTIONAL SHINGLES.
 - 3.3. ENCAPSULATED FOAM INSULATION BETWEEN THE ROOF RAFTERS (R-22 OR GREATER).
 - 3.4. WINDOWS AND DOORS MUST BE SEALED WITH FOAM OR CAULK.
 - 3.5. SILL PLATE MUST BE SEALED ON THE INSIDE WITH FOAM OR CAULK.
 - 3.6. ALL WALL PENETRATIONS TO THE EXTERIOR MUST BE SEALED WITH FOAM OR CAULK.
 - 3.7. BLOWER DOOR TESTING IS MANDATORY. NOT TO EXCEED 4 AIR CHANGES PER HOUR AT 50 PASCALS.
- DUCTS AND AIR SEALING**
 - 4.1. DUCTS MUST BE TESTED AND VERIFIED TO HAVE TOTAL LEAKAGE OF NO MORE THAN 4 FT³/MIN PER 100 SQUARE FOOT (OR 3 CFM IF AIR HANDLER IS NOT INSTALLED), EXCEPT WHERE AIR HANDLER AND ALL DUCTS ARE LOCATED INSIDE CONDITIONED SPACE. AIR HANDLERS AND FILTER BOXES MUST ALSO BE PROPERLY SEALED.
 - 4.2. HVAC AND DUCTWORK LOCATED OUTSIDE OF FIRE RATED ENVELOPE OF GARAGE.
 - 4.3. THE BUILDING ENVELOPE IS REQUIRED TO BE PROPERLY SEALED AND TESTED, AND VERIFIED AS HAVING AN AIR LEAKAGE RATE NO HIGHER THAN 3 ACH AT 0.20 INCH W.G. (50 PASCALS).
 - 4.4. SUPPLY AND RETURN DUCTS IN ATTICS SHALL BE SEALD AND INSULATED WITH R-8 WHEN DUCTS IS 3" OR GREATER, R-6 WHEN 3" OR LESS AND EXEMPT WHEN COMPLETELY INSIDE CONDITIONED SPACE.
- INSULATION:**
 - 5.1. ALL WINDOWS FENESTRATION U-FACTOR FOR CITY MUST BE 0.35, SKYLIGHT U-FACTOR 0.55 AND GLAZED FENESTRATION SHGC 0.25.
 - 5.2. CEILINGS MUST BE INSULATED WITH R-38, IF NO ATTIC SPACE R-30, THIS REDUCTION IS LIMITED TO 500 SQUARE FEET (46 M²) OR 20% OF THE TOTAL INSULATED CEILING AREA, WHICHEVER IS LESS.
 - 5.3. ATTIC ACCESS LADDERS AND OR HATCHES, MUST BE INSULATED THE SAME AS THE ATTIC AND HAVE A WEATHER SEAL
 - 5.4. ALL EXTERIOR WALLS MUST BE INSULATED WITH R-20 CANITY OR R-13 CANITY WITH R-5 CONTINUOUS INSULATION OR HIGHER.
 - 5.5. CRAWL SPACE WALLS MUST BE INSULATED WITH T-5 CONTINUOUS OR R-13 CAVITY INSULATION, WITH VAPOR BARRIER OVER EXPOSED EARTH.
 - 5.6. PIER AND BEAM OR ANY OTHER RAISED FLOOR SYSTEM MUST BE INSULATED WITH R-19 INSULATION OR HIGHER.
- HVAC SYSTEMS**
 - 6.1. TEMPERATURE CONTROLS MUST BE INSTALLED, INCLUDING A PROGRAMMABLE THERMOSTAT CONTROLLING THE PRIMARY HEATING AOD COOLING SYSTEM. MECHANICAL SYSTEM PIPING MUST BE INSULATED TO A MINIMUM OF R-3. HOT WATER PIPING 1/2" IN DIAMETER OR LARGER AND ALL HOT WATER PIPING IN CERTAIN APPLICATIONS MUST BE INSULATED TO R-3.
 - 6.2. PIPES CARRYING FLUID OVER 104' OR BELOW 55' MUST BE INSULATED WITH R-13.
 - 6.3. LIGHTNING:
 - 6.4. A MINIMUM OF 75% OF LAMPS IN PERMANENTLY INSTALLED FIXTURES MUST BE HIGH-EFFICACY AS DEFINED IN THE IECC.

CURRENT CITY CODES:

- 2015 International Building Code
- 2015 International Residential Code
- 2015 International Energy Conversational Code
- 2015 International Fuel Gas Code
- 2015 International Mechanical Code
- 2015 International Plumbing Code
- 2015 International Existing Building Code
- 2015 International Fire Code
- 2023 National Electrical Code



Xavier Chapa
Xavier Chapa Engineering/Surveying
Firm Number F-9156

09/02/2024

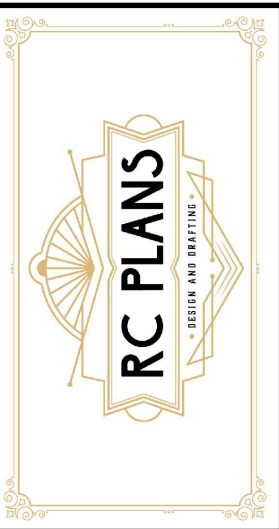

rcplans@outlook.com

All the information in these plans is provided by the client and / or builder, the designer only limits himself to draw required plans for building permits and doesn't supervise construction or control of quality of materials, therefore the designer does not assume any type of responsibility derived from this project. The project owner is recommended to have professional supervision of a qualified architect or engineer for the review of plans and building's construction.

RESIDENTIAL NEW ADDITION	FLOOR PLAN	RC PLANS	07/10/2024	3/16" = 1'-0"
USE:	PLAN:	DRAWN BY:	DATE:	SCALE:

ADDRESS:
**552 ARBOR BROOK LN,
COPPELL,
TX 75019**

PAGE NUMBER:
02

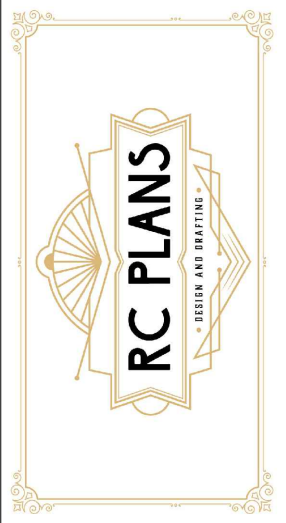

rcplans@outlook.com

All the information in these plans is provided by the client and / or builder, the designer only limits himself to draw required plans for building permits and doesn't supervise construction or control of quality of materials, therefore the designer does not assume any type of responsibility derived from this project. The project owner is recommended to have professional supervision of a qualified architect or engineer for the review of plans and building's construction.

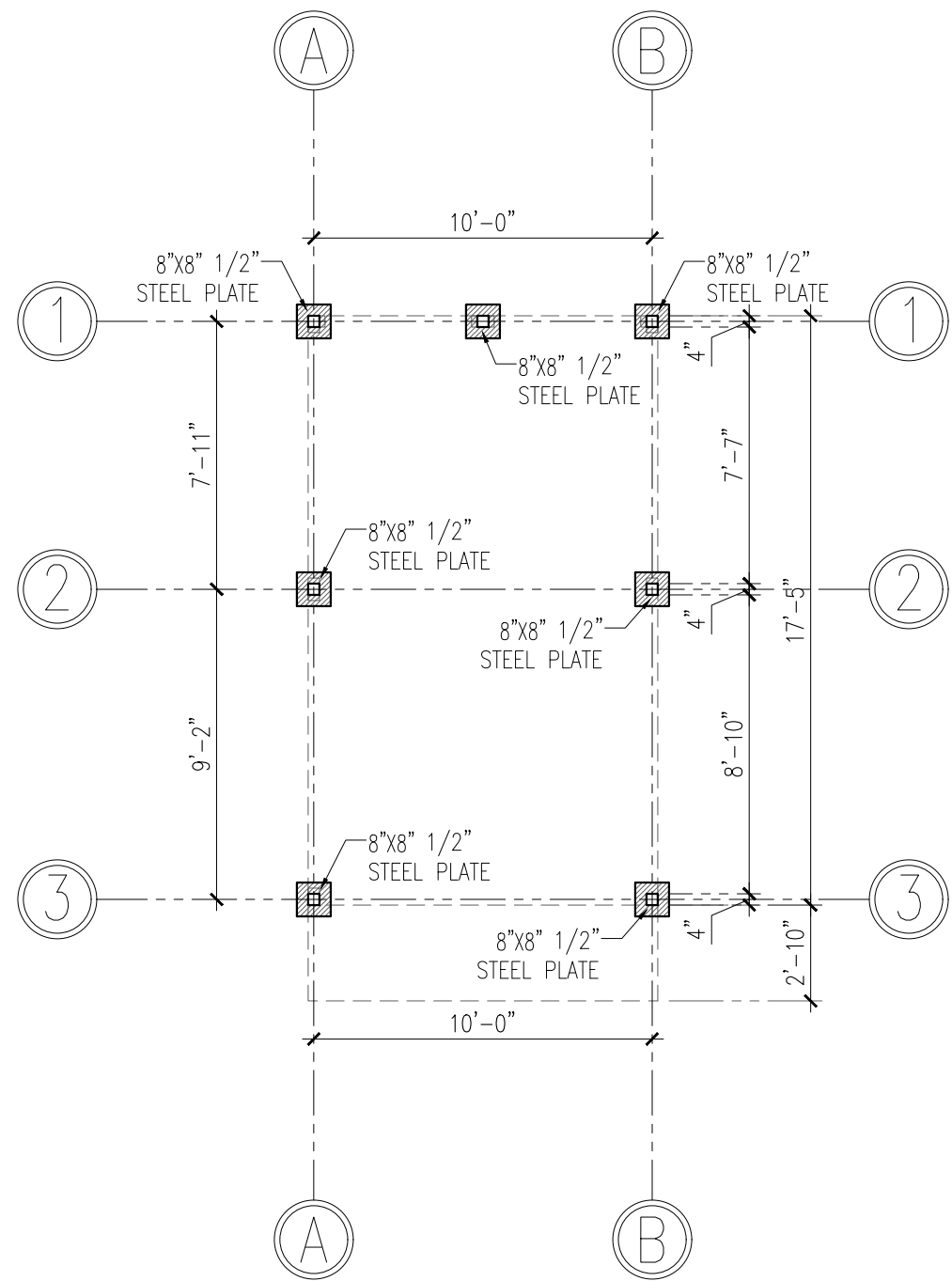

STEEL PLATE
SCALE 3/16" = 1'-0"

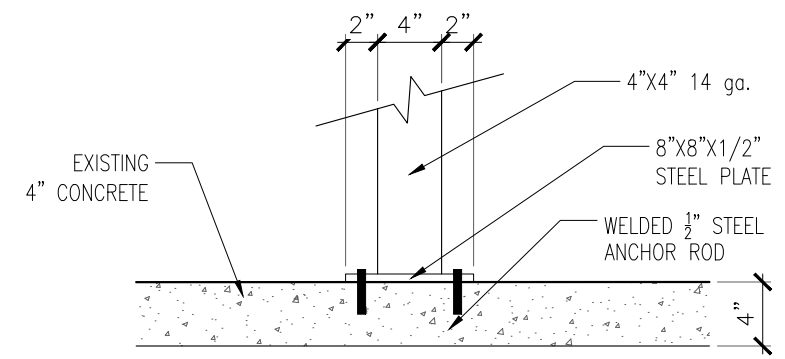

STEEL PLATE DETAIL
SCALE 1" = 1'-0"



Xavier Chapa
Xavier Chapa Engineering/Surveying
Firm Number F-9156

09/02/2024

RESIDENTIAL NEW ADDITION	FOUNDATION DETAILS	RC PLANS	07/10/2024	3/16" = 1'-0"
USE:	PLAN:	DRAWN BY:	DATE:	SCALE:

ADDRESS:
**552 ARBOR BROOK LN,
COPPELL,
TX 75019**

PAGE NUMBER:
03

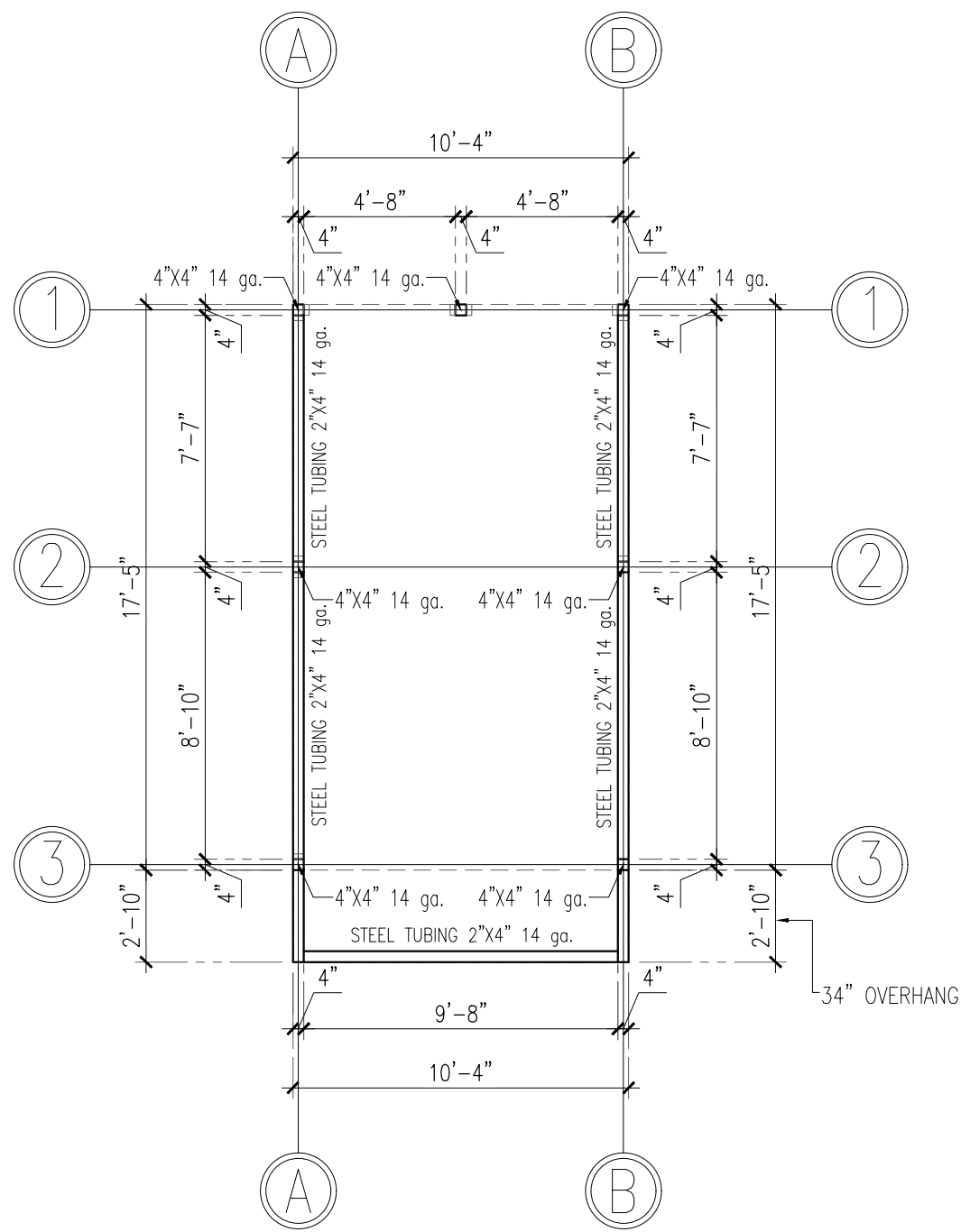

EAVE HEIGHT STEEL MEMBERS

SCALE 1/8" = 1'-0"

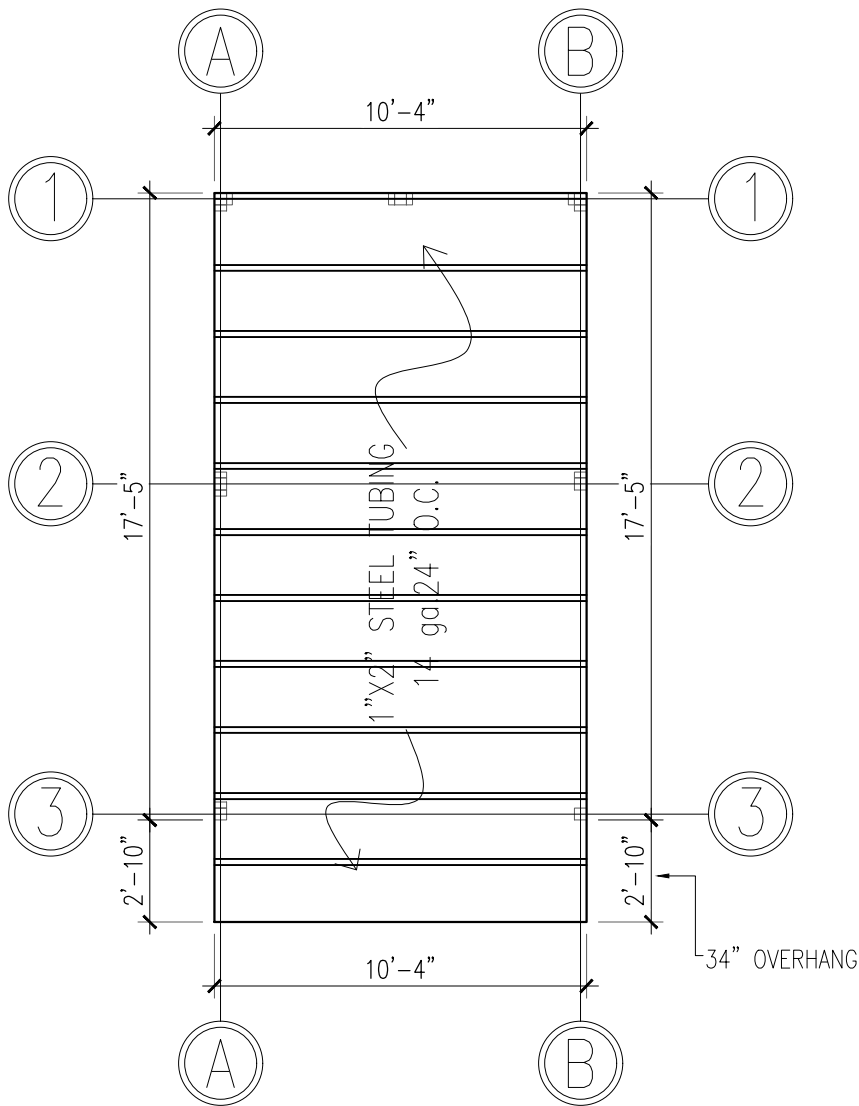

STEEL ROOF ASSEMBLY

SCALE 1/8" = 1'-0"

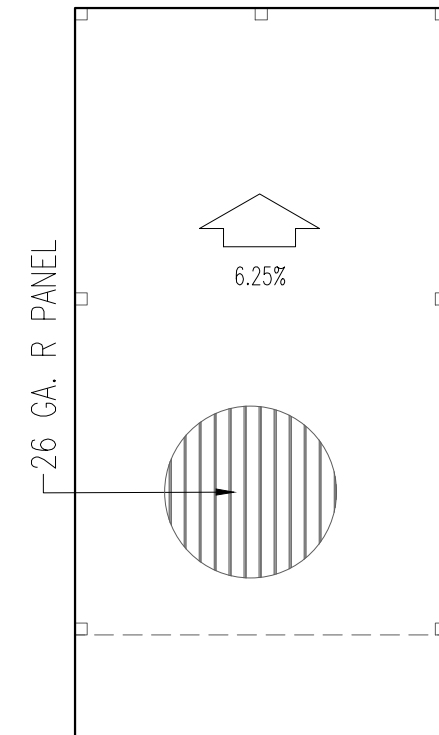

ROOF

SCALE 1/8" = 1'-0"



Xavier Chapa

09/02/2024

Xavier Chapa Engineering/Surveying
Firm Number F-9156

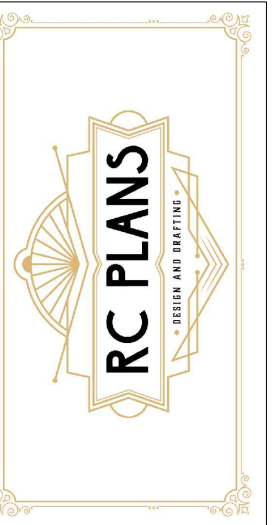

rcplans@outlook.com

All the information in these plans is provided by the client and / or builder, the designer only limits himself to draw required plans for building permits and doesn't supervise construction or control of quality of materials, therefore the designer does not assume any type of responsibility derived from this project. The project owner is recommended to have professional supervision of a qualified architect or engineer for the review of plans and building's construction.

RESIDENTIAL NEW ADDITION	FRAMING PLAN	RC PLANS	07/10/2024	3/16" = 1'-0"
USE:	PLAN:	DRAWN BY:	DATE:	SCALE:

ADDRESS:

552 ARBOR BROOK LN,
COPPELL,
TX 75019

PAGE NUMBER:

04



Xavier Chapa
Xavier Chapa Engineering/Surveying
Firm Number F-9156

09/02/2024

All the information in these plans is provided by the client and / or builder, the designer only limits himself to draw required plans for building permits and doesn't supervise construction or control of quality of materials, therefore the designer does not assume any type of responsibility derived from this project. The project owner is recommended to have professional supervision of a qualified architect or engineer for the review of plans and building's construction.

RESIDENTIAL NEW ADDITION	FRAMING DETAILS	RC PLANS	07/10/2024	N.T.S.
--------------------------	-----------------	----------	------------	--------

USE:	PLAN:	DRAWN BY:	DATE:	SCALE:

ADDRESS:

552 ARBOR BROOK LN,
COPPELL,
TX 75019

PAGE NUMBER:

05

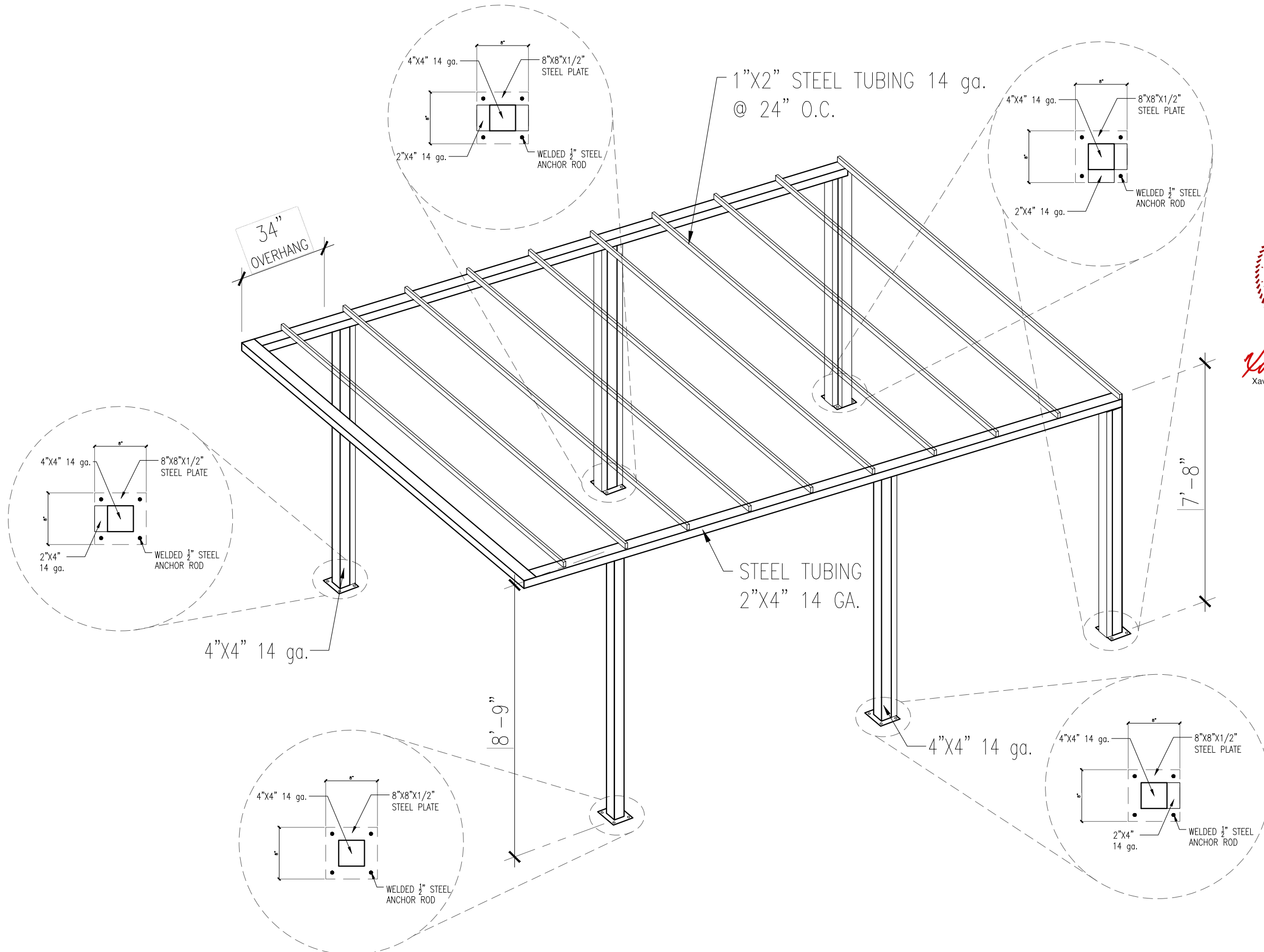

**ISOMETRIC CARPORT
DETAIL**

N.T.S.

STEEL:
ALL STEEL NOT OTHERWISE NOTED SHALL BE PER ASTM A572 (Fy = 50 KSI) PER LATEST AISC SPECIFICATIONS.

MACHINE BOLTS, ANCHOR BOLTS, AND THREADED STUDS SHALL BE PER ASTM A307, U.O.N.

HOLES: 1/16" GREATER THAN BOLT SIZE, EXCEPT FOR ANCHOR BOLTS WHICH ARE 3/16" GREATER THAN BOLT SIZE., U.O.N.

PIPE COLUMNS SHALL BE PER ASTM A35, GRADE B, Fy = 35 KSI, OR ASTM A501, Fy = 36 KSI.

TUBE STEEL SHALL BE PER ASTM A500, GRADE B, Fy = 46 KSI.

ALL WELDING SHALL BE PER AWS STANDARDS, LATEST EDITION. COPES, BLOCK AND CUTS: ALL REENTRANT CORNERS SHALL BE SHAPED, NOTCH-FREE, TO A RADIUS OF AT LEAST 1/2".

ALL WELDING SHALL BE DONE BY SHIELDED ARC METHOD. ALL WELDERS SHALL BE PROPERLY QUALIFIED AND AWS CERTIFIED FOR THE KIND OF WELD THEY PERFORM. SURPLUS WELD SHALL BE DRESSES OFF TO SMOOTH, EVEN SURFACES WHERE WELDS ARE EXPOSED TO VIEW.

ALL FIELD WELDING SHALL BE INSPECTED BY A TESTING LABORATORY APPROVED BY THE ENGINEER.

ALL STEEL NOT ENCASED IN CONCRETE OR MASONRY SHALL HAVE ONE SHOP COAT OR RED LEAD OR ZINC CHROMATE.

WELDING RODS SHALL BE LOW-HYDROGEN TYPE, E70.

ALL BUTT WELDED SPLICES IN MATERIAL THICKER THAN 5/16" SHALL BE INSPECTED BY A TESTING LABORATORY APPROVED BY THE ENGINEER, TO CERTIFY ALL SPLICES AS MEETING OR EXCEEDING STRENGTH OF MATERIALS SPLICED. COPIES OF TEST REPORTS AND LETTER OF CERTIFICATION SHALL BE SUBMITTED TO ENGINEER.

WELDS INDICATED MAY BE MAKE IN SHOP OR FIELD WITH APPROVAL.

CONCRETE EXPANSION ANCHORS: PHILLIPS REDHEAD CONCRETE ANCHOR BY PHILLIPS DRILL COMPANY, INC., OR HILTI CONCRETE EXPANSION ANCHORS.

OPEN WEB STEEL JOISTS AND JOIST GIRDERS:
STEEL JOISTS AND JOIST GIRDERS SHALL BE DESIGNED, DETAILED AND MANUFACTURED TO FIT THE DIMENSIONS AND LOADS INDICATED ON THE PLANS AND IN THE STRUCTURAL NOTES. ENDS OF STEEL JOISTS SHALL BE FABRICATED TO ACCOUNT FOR JOIST SLOPE AND END BEARING CONDITIONS. THE ENDS OF K-SERIES STEEL JOISTS SHALL EXTEND A MINIMUM OF 2 1/2" OVER STEEL END SUPPORTS.

DESIGN, FABRICATION AND ERECTION SHALL BE IN ACCORDANCE WITH LATEST EDITION OF STEEL JOIST INSTITUTE BY A MEMBER OF SJI APPROVED FOR THE TYPE OF JOIST BEING USED.

ALL STEEL JOISTS SHALL BE MANUFACTURED WITH A POSITIVE CAMBER AS RECOMMENDED BY THE STEEL JOIST INSTITUTE.

JOISTS AND BRIDGINGS SHALL BE INSTALLED IN ACCORDANCE WITH THE RECOMMENDATIONS OF THE STEEL JOIST INSTITUTE. BRIDGING SHALL BE WELDED TO THE LEDGE ANGLES OR TO WELD PLATES AS SHOWN ON THE STRUCTURAL DRAWINGS.

DO NOT DRILL THROUGH OR WELD TO JOIST OR GIRDER MEMBERS WITHOUT PRIOR APPROVAL. SEE DETAIL FOR ADDITIONAL WEB ANGLE REQUIREMENTS AT MISCELLANEOUS FRAMING CONDITIONS.

WHERE JOISTS OR GIRDERS ARE CUSTOM DESIGNED TO MEET MINIMUM LOAD REQUIREMENTS ON DRAWINGS, CONTRACTOR SHALL SUBMIT DESIGN CALCULATIONS AND DETAILED SHOP DRAWINGS BOTH BEARING THE SEAL OF A CIVIL OR STRUCTURAL ENGINEER REGISTERED IN THE STATE IN

EXPOSED STEEL ROOF DECK:
STEEL DECK INSTITUTE SPECIFICATIONS AND RECOMMENDATIONS APPLY.

MATERIAL, DESIGN, MANUFACTURE, AND INSTALLATION SHALL BE EQUIVALENT TO VERCO MANUFACTURING, INC., OR EQUAL, U.O.N.

DECK SHALL BE 1 1/2" DEEP, TYPE HSB, 22 GAUGE, PAINTED, WITH MINIMUM I = 0.183 IN⁴, S = 0.209 IN³, PER FOOT WIDTH OF DECK.

STRUCTURAL CONSTRUCTION OBSERVATION:
IT IS THE CONTRACTOR'S RESPONSIBILITY TO INSPECT ALL STRUCTURAL WORK FOR CONFORMANCE WITH THE CONTRACT DOCUMENTS. ANY STRUCTURAL CONSTRUCTION OBSERVATION PROVIDED BY OTHERS DOES NOT RELIEVE CONTRACTOR FROM THE APPROVED PLANS THAT ARE FOUND AT A LATER DATE AND ARE DECLARED TO BE SIGNIFICANT WITH ALL DISPATCH AT THE CONTRACTOR'S EXPENSE.

THE CONTRACTOR IS RESPONSIBLE FOR PROVIDING ADEQUATE FACILITIES FOR THE STRUCTURAL CONSTRUCTION OBSERVED, TO ALLOW HIM TO PERFORM HIS WORK SAFELY AND EFFICIENTLY.

WELDING OF ROOF DECK:
INTERMEDIATE AND END WELDS AT EACH TRANSVERSE SUPPORT (JOISTS, BEAMS, ANGLES, PLATES, ETC.):

EXPOSED ROOF DECK:
1/2" EFFECTIVE DIAMETER PUDDLE WELD IN FIVE VALLEYS OF DECK.

MARGINAL WELDS (SUPPORT PARALLEL TO CORRUGATIONS):
ROOF DECK WITH LIGHTWEIGHT INSULATING CONCRETE:
3/8" EFFECTIVE DIAMETER PLUG WELD, IN 14 GAUGE WELD WASHER, AT 24" O.C.

EXPOSED ROOF DECK:
1/2" EFFECTIVE DIAMETER PUDDLE WELD AT 24" O.C.

SIDE LAPS:
ROOF DECK WITH LIGHTWEIGHT INSULATING CONCRETE: N/A
EXPOSED ROOF DECK:
BUTTON PUNCH AT 24" O.C.

SHEAR TIE ANGLES, DRAG STRUTS, AND DIAPHRAGM CHORDS (SUPPORT PARALLEL TO CORRUGATIONS):
1/2" EFFECTIVE DIAMETER PUDDLE WELD AT 24" O.C.;
(SUPPORT PERPENDICULAR TO CORRUGATIONS):
1/2" EFFECTIVE DIAMETER PUDDLE WELD IN ALL VALLEYS OF DECK.
PERIMETER @ OPENING FRAMING:
1/2" EFFECTIVE DIAMETER PUDDLE WELD @ 12" O.C. ALL SIDES.

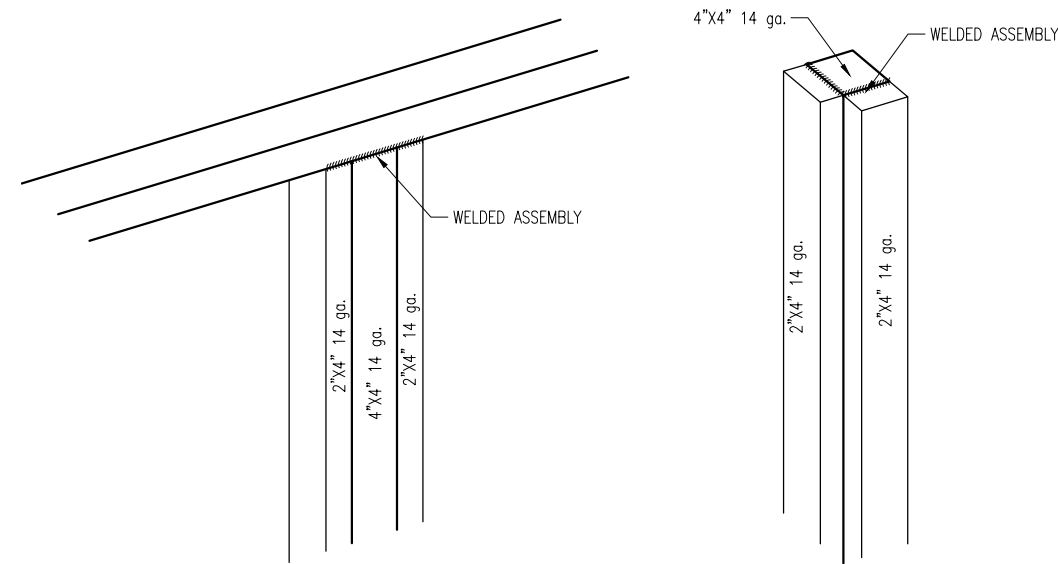

PILAR/CHORD ASSEMBLY

SCALE 3/4" = 1'-0"

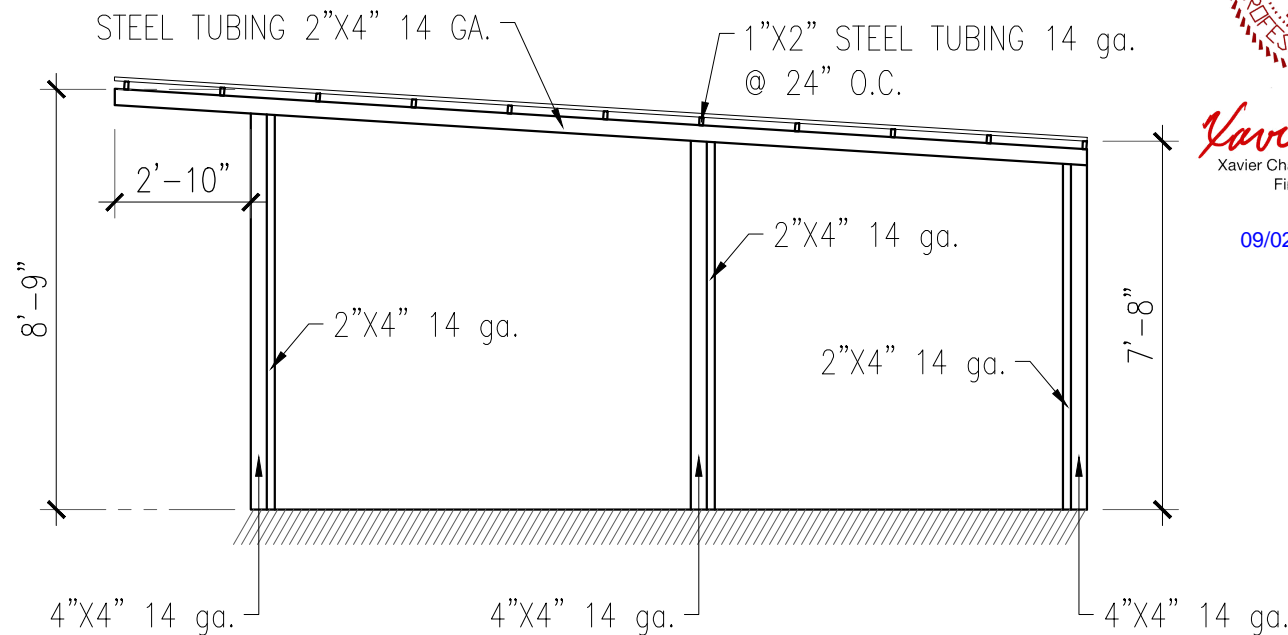

RIGID FRAME TYPICAL SECTION

SCALE 1/4" = 1'-0"

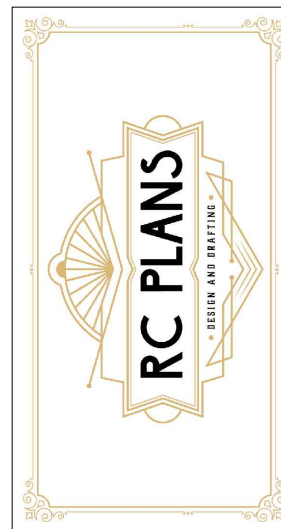

rcplans@outlook.com

All the information in these plans is provided by the client and / or builder, the designer only limits himself to draw required plans for building permits and doesn't supervise construction or control of quality of materials, therefore the designer does not assume any type of responsibility derived from this project. The project owner is recommended to have professional supervision of a qualified architect or engineer for the review of plans and building's construction.



Xavier Chapa
Xavier Chapa Engineering/Surveying
Firm Number F-9156

09/02/2024

RESIDENTIAL NEW ADDITION	FRAMING PLAN	RC PLANS	07/10/2024	3/16" = 1'-0"
USE:	PLAN:	DRAWN BY:	DATE:	SCALE:

ADDRESS:

552 ARBOR BROOK LN,
COPPELL,
TX 75019

PAGE NUMBER:

06